



P Z R 3 0 0 0   A m p l i f i e r

## *Owner's Manual*

---

Your New Pyle Pro PZR series P.A. Amplifier gives you the power and versatility you need in a professional sound system.

The amplifier's wide frequency response makes it suitable for amplifying music or vocal program material. It can be used for live bands, office paging systems, public announcements, or a variety of other installations.

## TABLE OF CONTENTS

- 1 Features and Controls, PZR3000
- 2 Installation Guidelines
- 2 Input Connections
- 2 Connecting a CD, DVD or tape player or tuner
- 2 Connecting an equalizer or signal processor
- 2 Stereo or Mono Inputs
- 2 Speaker connections
- 3 Bridged Mode Operation
- 3 Connecting to standard AC power
- 3 Mounting the amplifier
- 3 Turning the amplifier on
- 3 Using the power blue LED meter
- 3 Using the channel1 and channel2 output level controls
- 3 About the internal clip circuitry
- 4 Caring for your Pyle Pro Amplifier
- 4 Resetting the circuit breaker
- 4 Specifications
- 5 Limited warranty



Please read this manual thoroughly before you attempt to set up and use the amplifier. It contains a range of installation suggestions as well as instructions to ensure safe usage. Installed properly, you can expect years of trouble-free service from this product.

## FEATURES AND CONTROLS

### FRONT PANEL, PZR3000

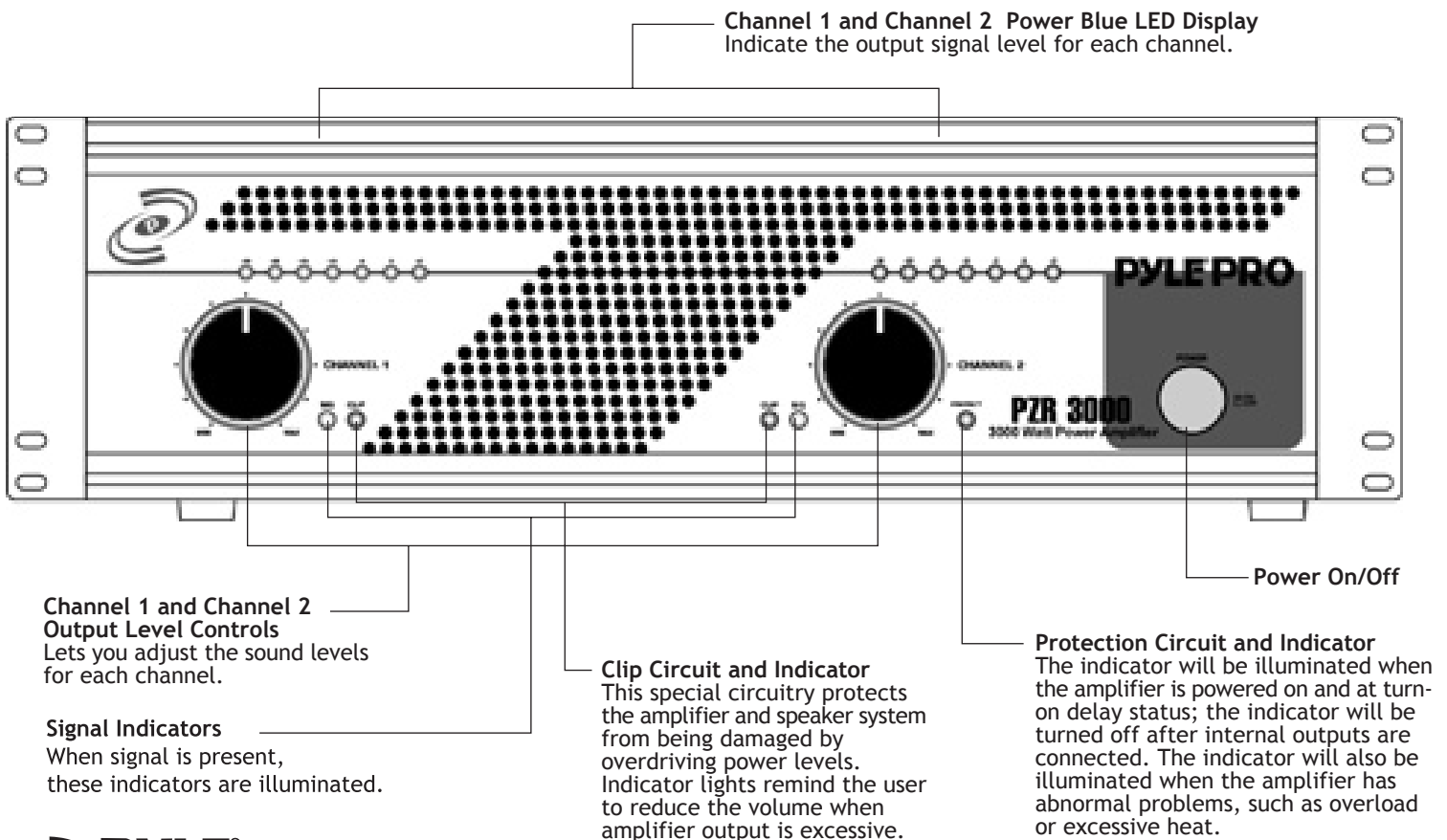

## REAR PANEL, PZR3000

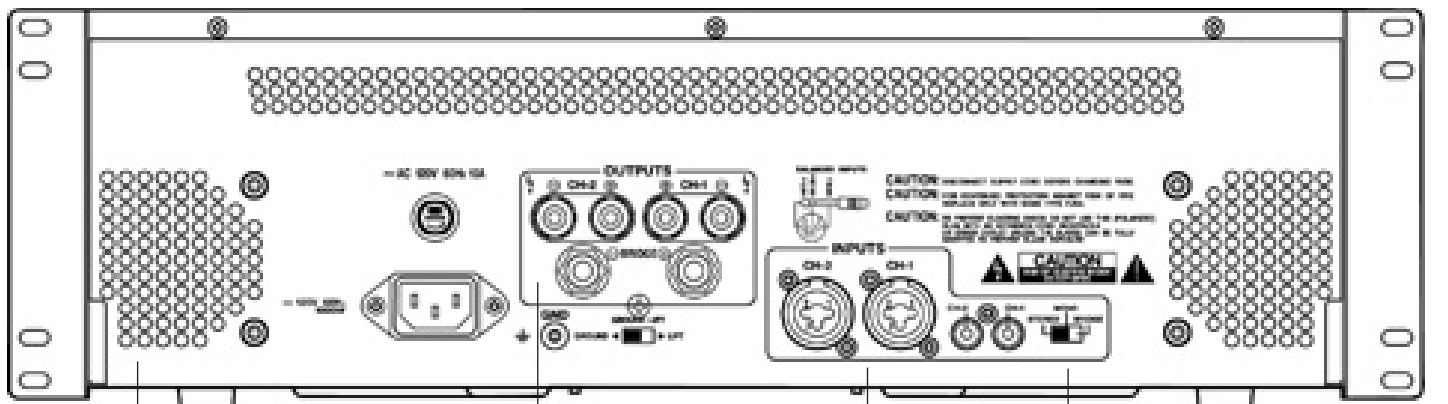

### Fan Cooling

Cooling system is automatically activated whenever amplifier is turned on. This forced air cooling system rapidly exhausts interior heat, reducing operating temperature and aiding performance.

### Speaker terminals

Permits hookup of A stereo pair of speakers or a bridged speaker via the wire terminals.

### Stereo/Mono Switch

Lets you select conventional stereo operation with a stereo input signal or bridged mono input mode.

### Input Jacks

Let you connect a variety of audio input sources via the balanced (XLR/6.35mm phone jack combinations) or unbalanced (RCA) inputs.

## INSTALLATION GUIDELINES

### Connecting the GND (Ground) screw terminal

Connecting a mixer or preamplifier may cause excessive noise or hum in the amplifier output. To prevent this, connect one end of a low-capacitance shielded wire to the amplifier's ground screw (on the rear panel). Then connect the other end of this wire to the ground terminal on the mixer or preamplifier enclosure.

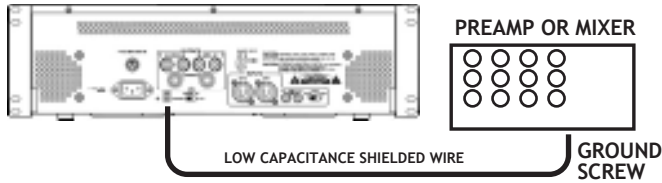

### Input connections

These amplifiers accept a broad range of **input sources**, including Compact Disc (CD) players; DVD, Cassette, Reel-to-Reel or other tape players; Radio Tuners; Equalizers; Signal Processors.

### Connecting a CD or DVD or tape player or tuner

In a normal installation, one would use the RCA JACKS for connecting a CD player, DVD, tape player or tuner.

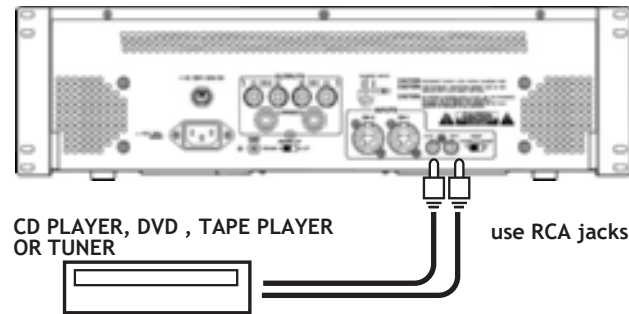

Connecting an equalizer or external signal processor  
Connect the processor's OUT to the amplifier's INPUT connectors.

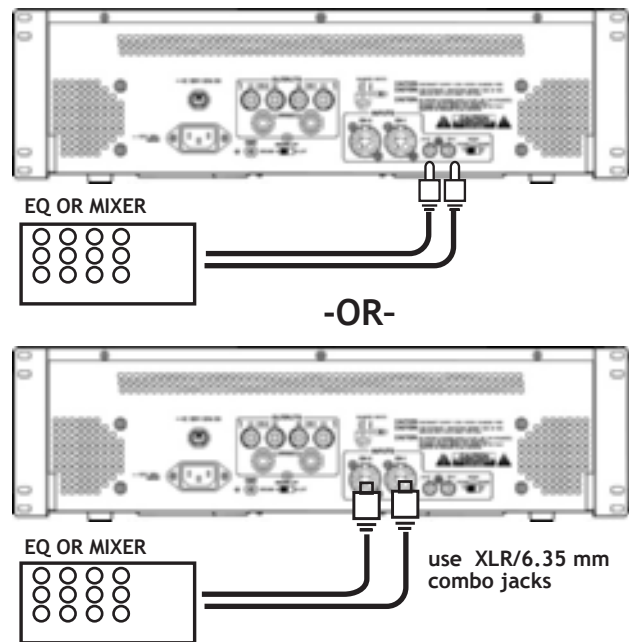

### Stereo or Mono Inputs

Your Pyle Pro amplifier can be operated in Stereo, Mono or Bridged mode, depending on the input source. If the input signal is mono, slide the Stereo/Mono/Bridged selector switch to MONO and the signal will be routed through both channels. If you wish to run the amplifier in bridged output mode, slide the switch to Bridged.

### Speaker connections

You can connect 4 Ohm, 8 Ohm or 16 Ohm speakers to Channel 1 and/or Channel 2 of the amplifier. If you connect two pairs of speakers, be sure to follow these guidelines:

- Speakers which are connected to the same channel are part of a pair, and must be of the same impedance.
- Speakers connected to different channels are NOT part of a pair, and can be of different impedances.

1. Prepare the speaker wire by removing about 1 inch of insulation from the end of the speaker wire you intend to connect to the amplifier. Then twist the exposed wire to secure all the wire strands.

*NOTE: Use 16-gauge speaker wire for lengths up to 25 feet; 14-gauge wire for lengths over 25 feet. It is recommended that you use the shortest length of wire possible.*

2. Connect the speaker wires to the speaker's positive and negative terminals.

*NOTE: Most speaker terminals are either color-coded or have a mark that indicates the terminal's polarity. Usually positive terminals are red or have a plus symbol (+), and negative terminals are black or have a minus symbol (-).*

3. Connect the speaker wires to the amplifier's left and right speaker terminals according to the terminal color polarity.

## STEREO OPERATION

SWITCH IN "STEREO" POSITION

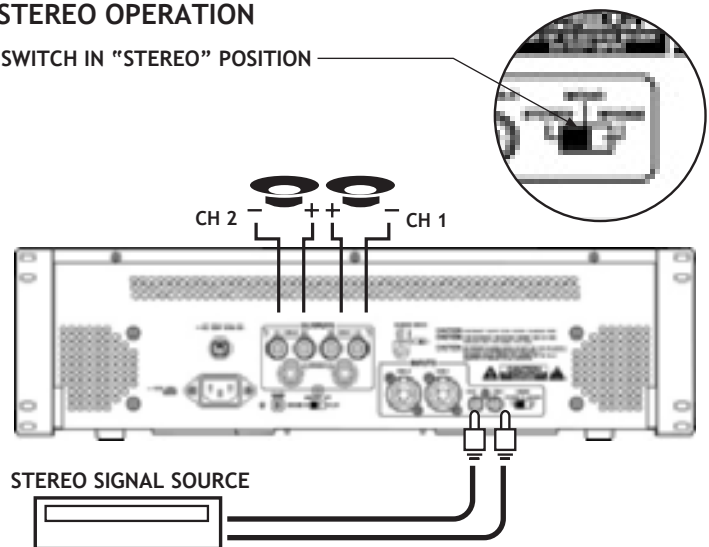

**CAUTION!** Do not use balanced and unbalanced inputs simultaneously!!



## MONO OPERATION

SWITCH IN "MONO" POSITION

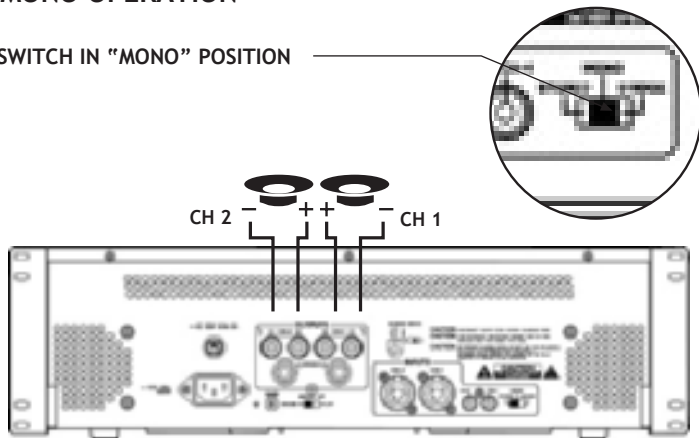

MONO SIGNAL SOURCE

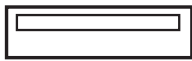

USE  
CHANNEL 1  
INPUT ONLY

*CAUTION! Do not use  
balanced and unbalanced  
inputs simultaneously!!*

### Bridged Mode Operation

This amplifier can operate in a mono bridged output mode, if your speakers can handle the following power output levels:

PZR3000: 3000 watts

As shown in the diagram below, connect the speaker's positive (+) to the amplifier's red speakers left (1/2) terminals and negative (-) to red speakers right (1/2) terminals.

The speaker right (+) on the amplifier is used as a negative (-) terminal for a bridged connection.

*NOTE: The extra amplifier output of 6.35mm phone jacks can not be used for the bridged connection. It can only be used in normal (non-bridged) operation as a stereo speaker output.*

## MONO BRIDGED OPERATION

SWITCH IN "BRIDGED" POSITION

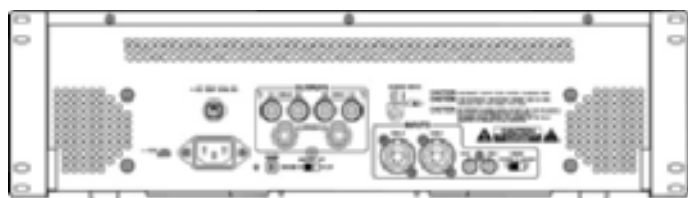
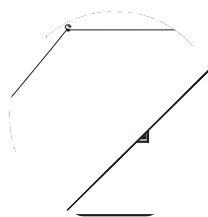

MONO SIGNAL SOURCE



USE  
CHANNEL A  
INPUT ONLY

### Connecting to standard AC power

After making all other connections, set the POWER switch to OFF position. Then connect the power cord to a standard AC outlet.

### Mounting the amplifier

This amplifier is designed to accept standard rack mounting installations. Two slots on each end of the front panel make it suitable for such an installation.

Tightly secure four mounting screws (not supplied) through these four slots and into your standard electronics equipment rack.

### Turning the amplifier on

1. Turn on the audio input source equipment which is connected to the amplifier INPUT jacks.
2. Set the amplifier's Channel 1 and Channel 2 output level gain controls to the minimum level settings.
3. Push in the power switch to turn the amplifier on.

### Using the power blue LED meters

The meter pointer position indicates the amplifier output power. For ease of reading in dark environments, the meter is illuminated.

### Using the Channel 1 and Channel 2 Output Level controls

Rotate output level gain clockwise to increase, or counterclockwise to decrease the output power. To get the best performance with the least sound distortion, always adjust the output level gain so the meter's pointer does not continuously exceed the extreme right of the meter's scale.

*CAUTION: It is possible to overdrive the amplifier by setting output level gain too high, which may cause damage or failure.*

### About the internal clip circuitry

Special clip circuitry incorporated into your Pyle Pro amplifier's design protects the amplifier and speaker system from being damaged from overdriving power.

Under normal conditions, the amplifier's clip indicator will flicker as the output power momentarily exceeds the level as set by the output level gain selector.

However, under excessive output conditions, the clip indicator lights remain on continuously, alerting you that the special clip circuitry has become active. When this occurs, you should simply reduce the output power level by rotating the Master Volume control counterclockwise.

### Caring for your Pyle Pro Amplifier

Your Pyle Pro Amplifier is an example of superior design and craftsmanship. The following suggestions will help you care for your amplifier so you can enjoy years of use:

- Keep the amplifier dry. If it gets wet, wipe immediately.
- Use the amplifier only in well-ventilated installations.
- Handle the amplifier gently and carefully - do not drop!
- Keep the amplifier away from dust and dirt.
- Wipe occasionally with a damp cloth to keep it looking new. Do not use harsh chemicals, solvents or detergents!

### Resetting the circuit breaker

This amplifier employs a circuit breaker for protection from power surges and short circuits. If the amplifier suddenly turns off or will not turn on, check the circuit breaker. If it is tripped, check and correct for a short or overload condition. Wait for the amplifier to cool, then press the circuit breaker RESET button on the back of the amplifier.

### Resetting the circuit breaker

This amplifier employs a circuit breaker for protection from power surges and short circuits. If the amplifier suddenly turns off or will not turn on, check the circuit breaker. If it is tripped, check and correct for a short or overload condition. Wait for the amplifier to cool, then press the circuit breaker RESET button on the back of the amplifier.

### Limited Warranty

All PYLE PRO products are carefully constructed and tested before shipment. Units purchased in the USA are warranted to be free of defects in material and workmanship for two (2) years from the date of purchase. This warranty is limited to the original retail purchaser of the amplifier.

Should the unit fail due to factory defects in material or workmanship, your unit will be repaired or replaced at the sole discretion of PYLE.

To obtain warranty service, you must first call our Consumer Return Hotline at (718) 236-6948 to obtain a Return Authorization Number. This R.A. # must appear on the outside of your package and on all paperwork relating to your return.

When returning the unit to us for warranty service, it must be carefully packed and shipped, prepaid, to:

R.A.#: \_\_\_\_\_  
 PYLE PRO Service Center  
 1600 63rd Street  
 Brooklyn, NY 11204

You must also include the following items with your return:

- A copy of your sales receipt or other proof of purchase
- A brief letter, indicating the problem you are experiencing with the product
- Include in your letter your return address, daytime phone number and R.A. number
- Also include a check or money order for \$20.00 for return shipping, handling and insurance, or provide your Visa/MC number with expiration date.

Our obligation under this warranty is limited to the repair or replacement of the defective unit when it is returned to us prepaid. This warranty will be considered void if the unit was tampered with, improperly serviced or subject to misuse, neglect or accidental damage.

Amplifier Specifications	PZR3000
Input Impedance, balanced (unbalanced)	20 k-Ohms (10 k-Ohms)
Continuous Output Power	
Stereo Mode	
20 Hz to 20 kHz, 8 Ohms	200W x 2
1 kHz, 4 Ohms	300W x 2
Maximum Power, 8 Ohms	230W x 2
Maximum Power, 4 Ohms	320W x 2
Peak Power, 8 Ohms	1500W x 2
Bridged Mode	
20 Hz to 20 kHz, 8 Ohms	600W x 1
1 kHz, 8 Ohms	600W x 1
Peak Power	3000W x 1
THD at rated output power	0.1%
Frequency Response +/- 3 dB	10 Hz to 50 kHz
Input Sensitivity for rated output power	1.0V
Signal-to-Noise Ratio A-Weighted	100 dB
Speaker Impedance	
Stereo	4-16 Ohms
Bridged	8-16 Ohms
Power Requirement	120 VAC, 60 Hz
Dimensions H x W x D, inches (mm)	5 3/16 x 19 x 15 3/8 (132 x 482 x 390)
Weight, lbs (kg)	31.9 lbs (14.5)



Place  
Stamp  
Here

---

---

---

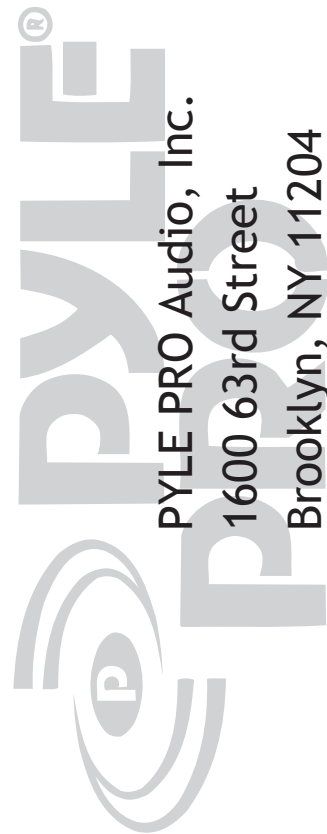

PYLE PRO Audio, Inc.  
1600 63rd Street  
Brooklyn, NY 11204

▼ Please complete warranty card, detach and return ▼

Thank you for purchasing this PYLE product. To activate your warranty, please mail this card within 10 days.



Name \_\_\_\_\_

Address \_\_\_\_\_

City, State ZIP \_\_\_\_\_

Model No. \_\_\_\_\_

Serial # (if available) \_\_\_\_\_

Date of Purchase \_\_\_\_\_

**Purchased at:**

- Music Products Store
- Sound Contractor/Installer
- Mail Order
- Catalog Merchandiser
- Other \_\_\_\_\_